

Introduction

Welcome

Welcome to the fascinating world of marquetry and to some of the techniques which will enable you to produce beautiful items from one of nature's most attractive materials - wood.

Dedication

This introduction to marquetry is dedicated to my many friends in the Marquetry Society who have helped and encouraged me to develop and improve *Marquetry Magic* and to my wife, Christine, both for her support and for putting up with the mess I seem to make so frequently.

Dedication

About the Author

Quentin Smith took up marquetry in 1987, joining the newly formed Thurrock Group of the Marquetry Society in Essex. He has exhibited regularly in the Marquetry Society's National Exhibition, receiving awards in pictorial, applied, miniature and portraiture marquetry. He is now eligible to compete in the Society's Premier Class and was a member of the judging panels for the 1995, 2001 and 2006 National Exhibitions.

About this Introduction

Marquetry is a complex subject with many facets. This introduction is just that, an introduction to some of the basics to get you, the keen beginner, under way. Should the marquetry "bug" bite, and I hope it does, you will be bound to want to find out more. By far the best source of information is other marquetarians, who can be contacted via the Marquetry Society. They will invariably offer copious advice, frequently contradictory! However, faced with two or three proposed solutions to your problem you can select the one with which you feel most comfortable.

Reference books on marquetry are available and a short, and incomplete, bibliography is included. Many of these books are hard-back, with sumptuous illustrations and prices to match. I recommend you obtain a copy via a library before ordering.

What is Marquetry?

Marquetry, also sometimes called intarsia, is the art and craft of producing pictures and decorative designs by the skilful use of the grain, figure and colour of thin veneers of wood and other materials. In marquetry the design is applied to a prepared base material, unlike the related craft of inlay where decorative bandings or designs are let into a solid item for embellishment.

The History of Marquetry

The origins of marquetry are uncertain. However hieroglyphs and paintings indicate that veneers were cut with bronze adzes and applied to caskets in Ancient Egypt. At this time mosaic work was also widespread, so it can be imagined that it did not take long for craftsmen to start experimenting with designs formed from different veneers.

In the 14th Century marquetry developed in Northern Italy as a method of decoration for

cathedrals and over the next few centuries schools developed in France, Germany and Holland. During the 16th to 18th centuries much exquisite work was produced to decorate furniture. Today there are some professional marquetarians but it is the amateurs who produce much of the finest work. Being unrestricted by commercial concerns they are able to develop new, frequently labour intensive, techniques to take our hobby to new standards.

The Marquetry Society

The Marquetry Society was founded in 1952 to further the development of the art and craft of marquetry, and now has some 1,000 members world-wide. There are over 30 marquetry groups affiliated to the Society, all keen to welcome new members and pass on help and advice to the enthusiastic beginner.

The Society publishes a quarterly magazine, *The Marquetarian*, which is widely acknowledged as the best specialist publication in its field. It hosts its National Exhibition in a different UK venue each year, together with a range of Open Days and Demonstrations where members gather informally to discuss their craft and enhance their techniques.

For details of the Society's activities and membership fees contact:

Neil Micklewright Hon. General Secretary,
Marquetry Society 14 Buntingsdale Road
Market Drayton Shropshire TF9 1LT
+44 (0)1630 656550

Web Site: www.marquetry.org

[Goto Contents](#)

Materials

Veneers

Method of Preparation

Veneers used to be sawn from logs, either by hand or by saw-mill, resulting in sheets of anything up to 1/4" thick and as much sawdust as usable veneer.

Today veneers are cut by heavy slicing machinery. Logs are pre-treated by soaking or steaming to soften the fibres and are then sliced by rotating the log or flitch against a blade. The cutting may be carried out at various angles to the growth rings of the log, resulting in different figures such as "crown cut", "rotary", "quartered" and "half-quartered". You need not concern yourself with these terms, but if you are interested in finding out more then descriptions are given in several textbooks.

Ecological Considerations

Much concern has been expressed in recent years about the ecological damage caused by logging of hardwoods, especially in tropical forests. However, much of the logging is done not to harvest the timber, but merely to clear the forest to provide arable or grazing land. To the dismay of the marquetarian and ecologist alike, the exotic woods are frequently burned where they fall. *Marquetry does not exploit these important natural resources and, in fact, may serve in some small way to preserve them.*

Firstly it uses the rare and exotic timber in the most economical way, displaying its beauty to the fullest extent. One large mahogany tree provides enough veneer to cover two football pitches. Also it is the gnarled and knotted wood, frequently of little use for solid timber, which yields the wild-figured veneers and burrs so prized by the marquetarian.

Secondly it gives value to the wood, making it worthwhile for local communities to preserve and manage their environment to provide a continuing resource. Indeed, many veneers now come from managed forests, where several trees are planted in the place of each mature tree felled.

Which Should I Use?

If you are making a kit picture, which is the easiest way to get started, the answer is simple - use the ones supplied! However you may prefer to obtain a selection of veneers and make your own interpretation of a picture or design.

It is difficult to suggest which veneers a beginner should obtain, as this will depend to some extent on the intended project. The marquetarian should, wherever possible, see what he or she is buying and not order "blind". Most local groups of the Marquetry Society have a "shop" with a selection of veneers, and traders frequently attend woodworking shows.

There are a number of veneers which the beginner would be advised to avoid in the early stages for the reasons given.

Ebony (*Diospyros celebica*) - Hard to cut by knife and expensive, but a beautiful veneer for game boards

Wenge (*Millettia* spp.) - As hard as nails and very difficult to cut by knife.

Mansonia (*Mansonia altissima*), **Iroko** (*Chlorophora excelsa*) and **Western Red Cedar** (*Thuja plicata*) - These all give a very irritating dust when sanded. *Mansonia* also fades quickly, which may spoil your picture.

Padauk (*Pterocarpus dalbergoides*) - A beautiful red colour, but one which is very prone to "bleeding" into the polish and giving nasty stains across your picture.

Birds Eye Maple (*Acer saccharum*) - Another beautiful veneer, but one which expands and distorts severely when wet. Anything larger than about an inch square requires special handling if water-based adhesives are used.

Tools and Equipment

Knife Handle

Any fine, sharp, straight-bladed knife is suitable for marquetry, and the choice of type is best left to the user.

The following are widely available, and widely used:

Swann Morton Craft Knife

A small and inexpensive plastic handle which holds the blade securely. It is supplied with blades, but will also hold the finer surgical scalpel blades. Some users find the knurled locking screw uncomfortable on the fingers.

Exacto craft knife

A round metal handle with a knurled locking ring. It is supplied with sturdy, straight edged blades.

Ernie Ives Craft Knife

Endorsed by one of marquetry's gurus, the Ernie Ives knife has a short, round, plastic handle which will support a range of blades firmly.

Swann Morton Surgical Scalpel

A range of several metal and disposable plastic handles, of which the "No: 3" metal handle is particularly popular. These knives are useful for large, straight cutting and for cleaning glue and tape from pictures, but are not really suitable for detailed cutting as too much of the blade is exposed which causes it to bend, and sometimes break, in use. One of these handles can be useful for holding blades whilst grinding new cutting edges.

Of course, some marquetarians make their own knives by grinding down broken hacksaw blades!

Knife Blade

The absolute beginner will be well served by any craft blade with a straight blade such as the Exacto blade or the Swann Morton craft blades. Swann Morton scalpel blades are also popular, the 10a and 11 sizes being most favoured.

However, after a little practice the general purpose blades may be found rather thick for fine work, and many marquetarians invest in a supply of the thinner "11E" blades. These are more expensive, and more brittle, but produce a fine cut and keep a good edge.

It is worth considering that some blades have a bevel on both edges, whilst others are only bevelled on one side. The aim of the marquetarian should always be to make a perfectly vertical cut and for this reason some may prefer to use a single-bevel blade.

Cutting Board

A firm, flat working surface is required, such as a sheet of 1/2" plywood. This needs to be topped with a softer material with a little "give" to protect the blade as it cuts through the veneer. A sheet of thick cardboard will suffice for the beginner, but even better is a piece of linoleum or vinyl floor tile.

There are several makes of "self-healing" cutting boards on the market which are very good and make ideal additions to the budding marquetarian's Christmas list!

Sharpening Stone

Even a top quality, surgical steel blade will soon lose its edge when used on hard veneers such as ebony or wenge. In general it is not possible to hone the beveled edges of the blade to produce a new edge, so a hard sharpening stone is required, on which the back of the blade is ground down to produce a new point.

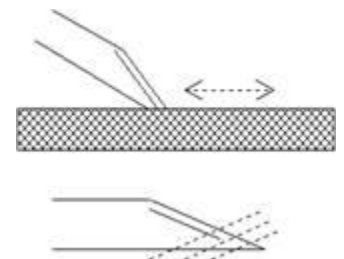

Straight Edge

A good metal straight edge is needed for cutting and assembling borders. It should be at least 12", and preferably 18" long. There are some very nice engineer's straight-edges with a raised

centre handle which lifts the fingers away from the "danger area" should the knife slip!

Tape

Many marquetarians have their favourite types and brands of tape, from the old-fashioned brown, "licky-sticky" parcel tape through to specific veneering tapes. For general purpose work a moderate tack masking tape, such as sold in DIY stores, is suitable. However it must be remembered that this will leave a sticky residue on the veneer if left in place for more than a few days or if used in a press.

Carbon Paper

Make sure you use a black carbon, not the blue type sometimes found in duplicate books. The blue carbon is waxy and tends to permeate into the grain of the veneer. Worse, these small traces will run and bleed when finishes or polishes are applied, causing a blue stain on your picture. If you are working on very dark veneers it is possible to buy white or yellow "carbon" paper which gives lines which are much more easy to see.

Adhesives

There are two separate "gluing" processes during the making of a marquetry picture. The first - gluing the small inserts into their "windows" as the picture is assembled - requires a simple PVA based wood-glue such as Evostik Resin W. The second process - gluing down the finished picture to its base-board - allows more scope for the use of different adhesive types, each having its champions. In general, the beginner will manage satisfactorily using the same PVA glue. Contact adhesives, such as Thixofix, can be useful for veneering curved surfaces, but they can be awkward to use, frequently smell unpleasant and may remain flexible for some time, causing cracking of the finish. Urea-formaldehyde resins, such as Cascamite, are favoured by some workers, but they require careful use and once set do not allow any "rescuing" should things go wrong.

[Goto Contents](#)

Basic Techniques

The Window Method

History

Early marquetry was generally cut using a fretsaw or "donkey" (a kind of horizontal fretsaw). This was really the only satisfactory way of working the heavy sawn veneers, which were up to 1/4" thick. Once thinner, machine cut, veneers were available it became possible to cut them using a knife. At the hobby end of the craft pictures tended to be cut a piece at a time and glued directly onto the baseboard - the so-called "stick-as-you-go" method. This generally lead to imperfect joints which required filling with stopping materials, though some of the leading exponents produced work of exceptional quality by this method.

It is not clear where the "window method" originated, as it rapidly became the method of choice for almost all marquetarians. It is the method recommended by the Marquetry Society and is described in detail in several books and in the methods sheet for the marquetry kits produced by the Art Veneer Company.

How it's Done - Basic

The design is traced onto the veneer using a black carbon paper. The shape is cut out, taking care to keep the knife upright so that the edge of the cut is clean and vertical.

The veneer to be inserted is then placed behind the resulting hole, or "window", and moved until the required effect of colour, figure and grain is seen. The insert veneer is then secured in place with a few small pieces of tape and the required piece is cut, using the edge of the "window" as a cutting guide. The insert piece is removed from its leaf, gently pressed into the "window" and taped lightly. Glue is rubbed into the joints to fasten the insert in place and shortly afterwards the tape can be removed. Each piece is added in this way, eventually ending up with the finished picture the thickness of a single sheet of veneer.

How it's Done - Detail

By way of practice, let's cut the small leaf design which follows. This is taken from the practice piece inserted in Art Veneers kits and though deceptively simple, introduces a range of cutting techniques. The background veneer should be light in colour, sycamore is ideal, but to make things slightly more difficult in order to bring out the problems you may encounter in a picture, try a more brittle veneer such as ash. The twig and leaf sections are cut from a darker veneer with a pronounced grain, such as walnut.

Notice the small arrows indicating the direction of the grain. Similar arrows will be found on designs from kit pictures, but if you decide to work from other subjects you will have to make your own decisions.

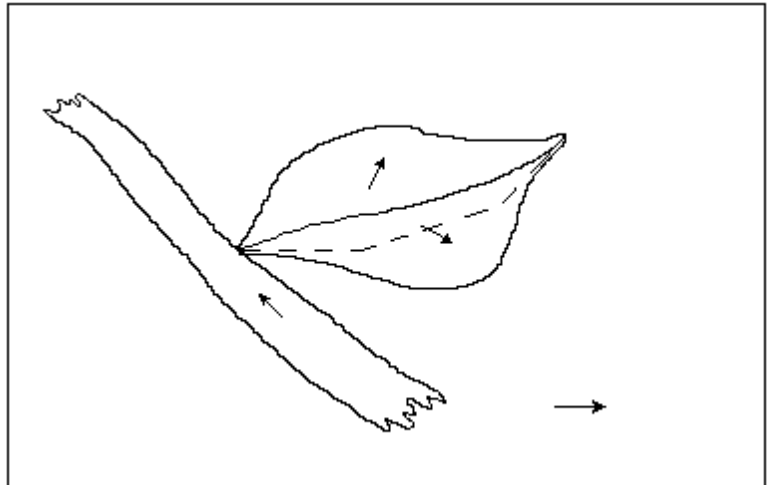

Attaching the Drawing

Take a piece of the ash veneer and attach the drawing to the top edge with a piece of tape like a hinge. This allows the drawing to be moved out of the way while cutting takes place, but to be swung back over the veneer in perfect register when required for tracing the next part.

Lightly sand the surface of the veneer with a piece of fine garnet paper and then trace through the design carefully using carbon paper and a sharp pencil. Don't press too hard, just enough to transfer the design clearly.

Cutting the Window

Start by cutting out the top half of the leaf, taking care to keep the knife blade vertical all the time. Most beginners try to cut by starting at the point furthest from them and drawing the knife towards them whilst trying to follow the carbon line. This tends to cause the knife to

wander as it encounters the grain of the veneer.

A better method is to cut in a series of steps. Start by making a small cut on the leaf outer edge, by the twig. This cut is really just a stab, with the blade held almost vertically, and cutting edge pointing down the leaf towards its outer point. Be sure to position the work to suit your cutting style. Having made this cut, turn the work round so that the leaf is pointing away from you. Gradually extend the cut along the leaf edge by moving about 5 mm along the edge and then cutting back towards the existing cut. There is little chance for the knife to slip over such a short distance and it will follow the existing cut even if it does not go right through at this time. Do not try to cut right through the veneer in one go, but work smoothly and gently so that you keep in full control. Continue to the outer point of the leaf.

Avoiding Glue-Lines

When we come to the "vein" side of the top half of the leaf we really do not want to cut exactly to the line. If we do, we will have glue just where we want to cut when inserting the second half of the leaf. Therefore cut below the line, in the area of the bottom half of the leaf - as shown by the dotted line. The excess will be cut away when we make the window for the second part of the leaf, so the cuts at this side can be simple straight lines.

Making the Window

Once you have cut right round the top half of the leaf the piece should drop out. It probably won't though, because it will be held by fibres which have not been completely cut. Do not force out the piece but carefully ease it up to see where it is catching and cut through again until the piece comes out cleanly. The aim is to produce a neat window with vertical sides and no stray whiskers around the edge.

Cutting the Insert

Take the piece of walnut veneer and lightly sand the face side. Position it behind the window and move it about until the grain is running in the right direction and you are happy with the appearance. This is the advantage of the window method - you can see exactly what you are going to get, and try several veneers without wastage.

Once you are happy with the position apply a few small pieces of masking tape at any convenient points to hold the two veneers together. If you study the grain of the veneer you will see that at the twig end of the leaf the grain runs right into the point, at the outer end however the grain runs across the point and in this area pieces will be very prone to breaking away. To avoid this, stick a piece of masking tape under the outer point. The pieces may still break, but will stay attached to the tape and can still be used.

Holding the knife almost vertically and keeping it close against the edge of the window, prick the design onto the dark veneer. Keep the side of the knife blade tight against the edge of the window when marking out the insert, and if using a single bevel blade keep the non-bevelled side against the window edge. Keep the blade vertical and gently "prick" through the shape. Don't try to cut right through, concentrate on marking all the line, especially around tricky curves. The line of marks should just be visible on the underside of the insert veneer. If any areas appear to have been missed, mark them again.

Once the entire outline is marked, remove the lower veneer and cut out the insert by carefully following the marks. Again, the object is to achieve a piece with clean, vertical sides.

Fitting the Insert

Marquetarians differ whether the insert should be fitted from the front or the back. Add to this that some people cut their picture from the front while others cut in reverse from the back and there are lots of options! I prefer to cut from the front - so that the picture is seen as it will finally appear - and to fit the insert from the back. This usually produces joints which are tighter at the rear surface than at the front, which means that as the picture is sanded down ready for polishing, the joints get better!

Lay the insert piece on the board and then position the background piece above it. Carefully manoeuvre the window so that the insert fits in from the back. Press the insert in carefully, easing it gently with the point of the knife if necessary. Place a piece of tape over the insert on the front of the work and then gently remove any tape from the back of the insert and background. Take special care where there are any short cross-grain pieces.

Once the tape is removed, apply a small blob of PVA glue to the back and work it into the joint using a firm metal pusher - the handle of a Swann Morton No. 3 scalpel is ideal. The glue causes the fibres to swell slightly and forms a tight joint. Rub the glue with your finger until it is no longer wet, then remove any excess glue by gently scraping with a blade held across the surface (don't use your best 11E blades for this!) so that the back of the work is kept clean. Any build up of glue will be more difficult to remove once it has fully hardened, but it must be removed to be sure of getting good adhesion to the baseboard.

Allow the glue to set for a few minutes more (when working on a picture you could be cutting another window elsewhere) and then remove the tape from the face taking care not to pull out any small pieces.

Completing the Practice Piece

Trace the leaf vein onto the first insert and then cut out the second part of the leaf - this piece must be a good fit all round as no over-cutting is possible. Notice how by having over-cut the first leaf piece you now get a clean edge along the leaf vein. Cut in the second leaf piece as above.

The twig is also cut in exactly the same way, but this time it is the background, and not the insert, which has small cross-grain pieces which may break away. Prevent this happening by taping the back of the work before cutting the window and by taking great care when pricking round the detailed ends of the twig.

Advantages

The key advantages of the "window" method are two-fold. Firstly the insert veneer can be moved behind the window to show the exact effect, thus allowing the best use of the grain, colour and figure of the veneer. Secondly the window is used as the template, therefore the insert must fit perfectly (?) into the window.

More Tips

Order of Cutting

In general, pictures should be cut from the background to the foreground. Thus in this simple picture the hills would be inserted first, as one piece, before the tree. If the hills are inserted after the tree the grain on the two pieces may not line up and look distorted.

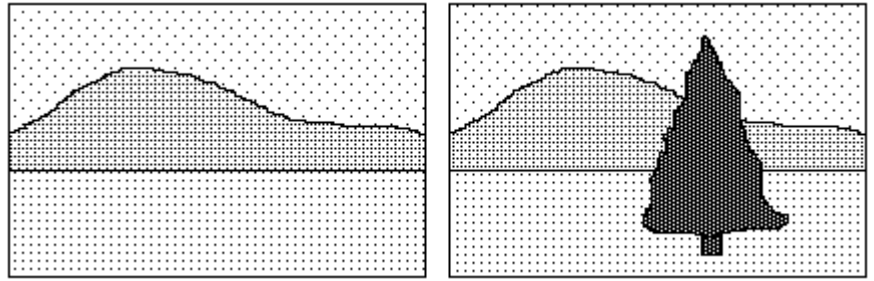

Filling "Holes"

If cutting pieces with hollow centres - such as the letters "O", "Q", "D", etc. always ensure that the centre matches the grain direction of the background. Thus for the letter "Q", first cut the outline, but retain the "waste" removed. Cut and insert the veneer for the letter. Cut the window for the centre of the letter, then tape the waste piece of background previously removed behind the new window and cut the insert.



Borders & Stringers

Introduction

Though there is no hard and fast rule, marquetry pictures are generally not "framed". Instead, the face of the picture includes a decorative border finished flush with the surface. This border may include thin strips of contrasting veneer called "stringers" to add decorative value. Commercial decorative bandings are available, but these can introduce additional problems as they are frequently thicker than standard veneers.

Choosing the Veneers

Selecting veneers for borders is at least as difficult as selecting them for use in the picture. There are (again) no definite rules, but the following guidelines are worthy of consideration.

- The border should enhance the picture, not detract from it.
- Using veneers for the border which are also used in the picture gives an overall sense of unity.
- Light borders project the picture forward, whilst dark borders tend to give a feeling of depth.

A Simple Cutting Jig

Nothing looks worse than stringers and borders which are not uniform. Therefore great care must be taken over cutting. The best method is to construct a simple cutting jig. This may take a little time at first, but the effort is soon repaid. All that is required is a flat board, large

enough to accommodate the cutting mat, with a metal or sturdy wooden straight edge fastened to one long side so that it is proud of the surface.

Parallel Cutting Using the Jig

The veneer to be cut is first trimmed using a sharp blade and a metal straight edge, then this newly cut edge is butted up against the stop on the board. The metal straight edge is placed on the veneer and pushed up against two equal-sized spacers, as shown.

Taking care to keep the veneer tight against the stop, and the rule tight against the spacers, the strip of veneer is carefully cut using gentle strokes of a sharp blade. Coins, used either flat or on edge, and various size washers or hexagonal nuts make good spacers and a varied collection can soon be amassed.

Remember that four matching pieces are required, which must be at least two total border widths longer than the picture dimensions. In case of later error, prepare six strips each as long as the longest side of the picture plus two border widths. If an error is made on a long side the "waste" may still do for a short side, giving plenty of scope for recovering mistakes! If all goes well, the left-overs can be kept in a small library which will help when choosing borders for later projects.

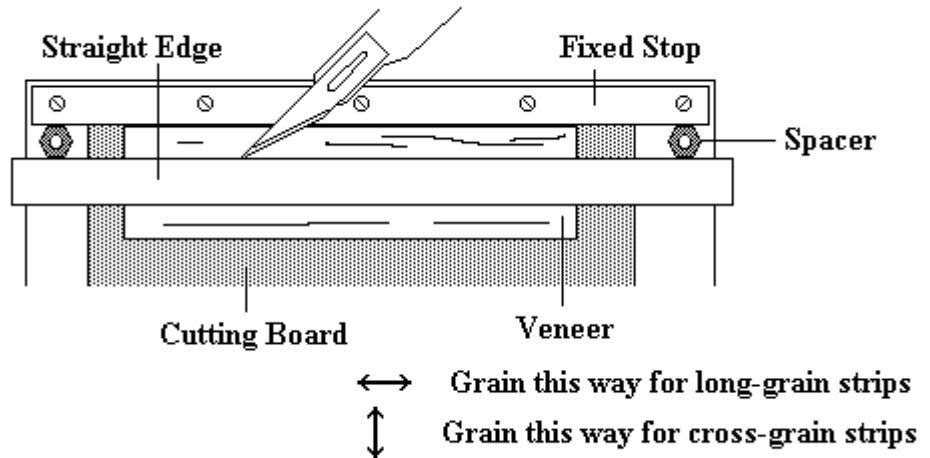

Assembling Borders & Stringers

Complex borders containing stringers are best assembled into units before being attached to the picture. Each element of the banding is cut on the jig using appropriately sized spacers. In order to prevent bending the assembly is best prepared on tape attached to a metal

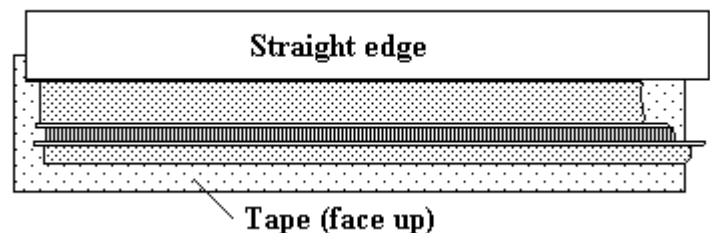

straight edge as shown.

Some marquetarians would leave the banding on tape until required, but I find it useful to rub in a little PVA glue to keep the strips together during handling. Most of the tape can then be removed, except for small protective pieces at each end, which reduces the chance of tape residue being left on the veneer.

How to Attach Borders

There are (at least) two schools of thought on the best way of gluing down pictures and attaching borders. Having tried several methods, I am undecided and frequently work without borders!

Method 1 - Attaching the Border to the Picture Before Gluing Down

Square up the picture by first trimming one side using a straight-edge, then cut the opposite side exactly parallel by measuring or using large spacers on the cutting board. Carefully cut one side at right-angles to the first edge using a set square, then cut the fourth side by measurement from the opposite side or using spacers.

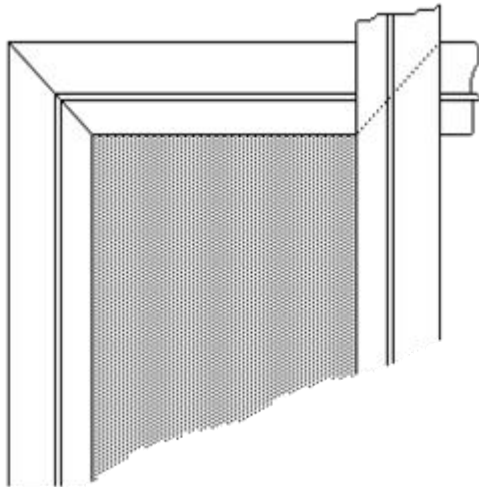

Check that the picture is a true rectangle by measuring the diagonals, which should be equal and adjust as necessary.

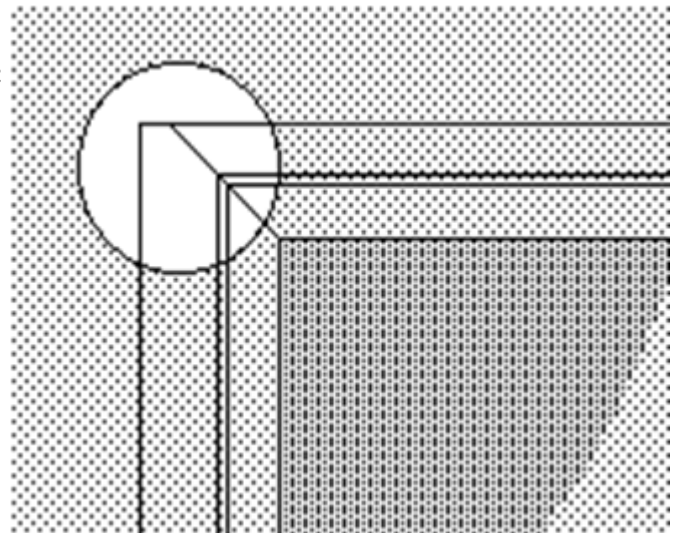

Tape border assemblies to each side, overlapping them in the corners. Cut carefully through both thicknesses

*s of
border
from the
corner of
the picture
to the
outer
corner as
shown (DO
NOT cut
inwards as
any slip will
damage
the
picture).*

Pros & Cons:

With this method it is relatively easy to achieve acceptable mitres, but rather difficult to stick the final assembly accurately onto the baseboard, with the result that the mitres may not exactly match at the corners.

Method 2 - Add the Borders After Gluing Down

Cut the picture square, then glue it onto an oversize baseboard (clean up any glue which oozes onto the face of the board).

Use a parallel sided strip, just wider than the intended border, to mark the baseboard and then cut the baseboard to size. Sand the edges true (see Edges and Corners) and apply veneer to the back and edges (see Ironing On. Tape a border assembly to two adjacent edges of the picture, overlapping at the corner, and cut a mitre (which should run exactly to the corner of the board if the board is cut correctly).

Do not remove the edges, but add further borders, cutting the mitres as you go. Gently hinge up the borders on their tape, apply glue to the baseboard underneath and fold the borders back. Apply small pieces of tape to pull each mitre tight and place in the press.

Baseboards

Materials

There are several considerations when selecting baseboard materials. Firstly the baseboard should not be too thick, especially if the picture is small. It is surprising how many of the miniatures exhibited at the Marquetry Society National Exhibition are mounted on thick boards which spoil the overall balance of the picture. As a rule of thumb, pictures of approximately A5 size (5.83" x 8.27") and smaller should not be mounted on boards thicker than about 6 mm (0.236") and pictures between

A5 and A4 (8.27" x 11.7") should not be on thicker board than 12 mm (0.472").

There are really three choices of material - solid timber, plywood and composites.

Composite Materials

These comprise man-made boards such as chip-board and "medium density fibre-board" (MDF). MDF is both easy to work and stable in use and the beginner is strongly recommended to use this material for early projects. MDF is available in various thicknesses, 6, 9 and 12 mm being the most common and useful.

In general, chip-board is too uneven to be of much use as any irregularity will tend to "telegraph" through and show on the final surface of the work.

Plywood

Plywood is a suitable baseboard material, though care should be taken to select high-grade plywood with a well prepared surface. It may be necessary to fill gaps in the edges with a filler to ensure good adhesion of edge veneers. It can be helpful to cut the plywood so that the grain direction of the plywood surface is at 90° to the predominant grain direction of the picture, in order to avoid warping.

Solid Timber

Surprisingly, this is probably the least suitable material on which to mount pictures. Firstly it is rather wasteful to use expensive timber when most of it is going to be covered with veneer and secondly it is more prone to warping than the man-made materials.

The experienced wood-worker may like to experiment with solid baseboards for items such as game boards as it is possible to produce attractive edge mouldings using routing equipment. However, such techniques are outside the scope of this document.

Cutting and Preparing

Edges and Corners

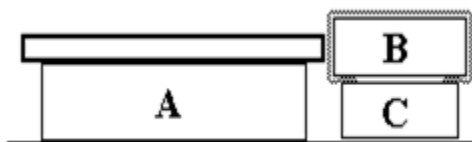

Baseboards should be carefully cut ensuring that all corners and edges are accurately square. The edges should be smoothed without "rolling over" and to achieve this they should be sanded using a sliding block as shown.

Place the baseboard on a block (A), which should be of such a size that the board is well supported, but has its edge overhanging. Wrap a piece of medium grade garnet paper around a block (B) and place this on another block (C). It is important that the facing edge of block (B) is exactly upright. Place the entire assembly on a smooth surface and then sand the edges by sliding blocks (B) and (C) together against the board edge. Take care only to move in a straight line, otherwise the corners of the board may become rounded.

This is a simple and useful technique which we shall see again when the edges of the picture have to be sanded.

Plywood may have occasional gaps in the edge where small pieces of the in-fill timber have broken away during cutting. Such gaps should be filled with a decorating filler or plastic wood and allowed to dry before preparing as above. If the gaps are not filled there will be areas of the edge veneer which will be "floating" and will therefore be difficult to sand and polish

satisfactorily.

Surface

The surface should be prepared to ensure good adhesion. MDF in particular has a high content of adhesive which tends to form a glaze on the surface. This needs to be removed by sanding lightly with a medium to coarse grade of sandpaper. Remember to prepare both surfaces of the board and take care not to round off the corners or edges. Some marquetarians suggest using a toothing plane or a fine hacksaw blade to roughen the surface of the baseboard and provide a "key" for the adhesive. In my opinion this is unnecessary if a reasonably coarse sandpaper is used.

Edges & Backs

Why Bother?

Having spent so much time working on the face of your picture you may feel less inclined to address your attention to the edges and back. However, these important areas should not be overlooked.

As the picture will be mounted on a baseboard between 6 and 12 mm thick the edges will be easily visible when the picture is displayed. Therefore they should be finished in a veneer which matches the border. The back will not be visible, but must at least be veneered in order to balance the "pull" of the picture veneers which may otherwise warp the board. It is not essential to polish the back, though conventionally marquetarians do polish the backs of pictures to the same standard as the face.

Choice of Veneer

On a initial projects, the beginner is recommended to use the same veneer for edges and borders. This results in a simple and pleasing overall effect. However there are other possibilities with which you may wish to experiment.

Contrast Edges

Instead of matching the border veneer, edges of contrasting tones can be used. Some care is required to make suitable selections but, for example, black edges can look effective on "Japanese" style pictures. Instead of matching the border veneer, edges of contrasting tones can be used. Some care is required to make suitable selections but, for example, black edges can look effective on "Japanese" style pictures.

Picture Edges

An interesting effect can be achieved by carrying the picture round onto the edge of the board. This initially requires the picture to be cut oversize so that the edge strips can be removed. Great care is required to ensure all the edges and the face are stuck on accurately so that the design lines up, but this is useful practice to prepare for applied marquetry projects such as jewellery boxes.

Choice of Grain Direction

Long-Grained Edges

The simplest edges use straight grained veneer with the grain running along the picture edge.

These edges are simple to apply and to sand and polish, however there are other possibilities.

Cross-Banded Edges

In these, edges the grain of the edge veneer runs across the edge from the front to the back of the picture. They are relatively simple to use except that more care is required to prevent the edge strips breaking during application. Cross-banded edges allow the use of veneers from sheets which are not as long as the picture edge, as joints running in the direction of the grain are virtually invisible. They also wrap well around curved surfaces, for example the edges of round pictures.

"Solid" Edges

When the picture is cut into a single background sheet an interesting effect can be achieved by using a pair of long-grain and a pair of cross-grain edges, such that the edge grain appears to be an extension of the grain on the picture face.

The overall effect mimics the use of a solid piece of timber, though the effect is lost if one stares at the corners too much!

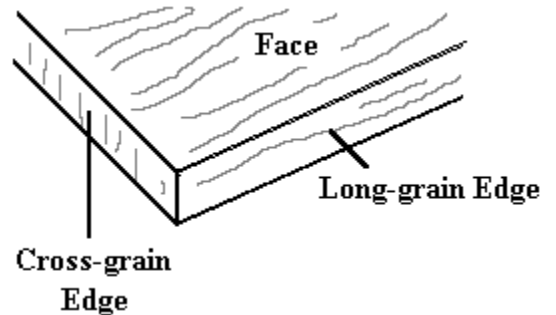

Order of Application

In order that the least number of joints are visible the back and edge veneers should be applied in the order - back, then top and bottom, then sides. The back veneer can be applied at the same time as the picture if the picture borders are to be applied later, otherwise the back should be applied first.

Applying the Back

Method 1 - Ironing On

This is a technique which the beginner should find relatively simple, but which is only really suited to baseboards up to about A5 size.

Cut the backing veneer just oversize - about 2 - 5 mm larger all round than the baseboard. Apply a thin layer of PVA adhesive to the back of the veneer and allow to dry until the glue goes transparent. This process can be accelerated using a hair-dryer if necessary. Some veneers tend to curl up when wet and may need to be taped down onto a board at the edges until the glue is dry. This is a technique which the beginner should find relatively simple, but which is only really suited to baseboards up to about A5 size. Cut the backing veneer just oversize - about 2 - 5 mm larger all round than the baseboard. Apply a thin layer of PVA adhesive to the back of the veneer and allow to dry until the glue goes transparent. This process can be accelerated using a hair-dryer if necessary. Some veneers tend to curl up when wet and may need to be taped down onto a board at the edges until the glue is dry.

Similarly coat the baseboard with a thin layer of adhesive and allow to dry. Some materials, MDF in particular, are very thirsty on adhesive and therefore a further thin layer should be applied and allowed to dry.

Place the baseboard face down (glue side up) and position the back veneer in place, adhesive surfaces together. Place a sheet of brown paper over the veneer and then gently iron on from one corner using a domestic iron (non-steam) set at around its middle temperature setting - "wool" on my iron. The heat softens the adhesive and bonds the surfaces together. Work smoothly over the board, avoiding prolonged heating in any one area.

Once all the veneer has been ironed on, remove the paper, turn the baseboard over onto a flat surface and apply a weight until the board has cooled (the adhesive will not "grab" fully until the board cools).

Examine the cooled board for any areas where the veneer has not adhered well. These can be ironed again and should stick provided both surfaces were correctly coated with adhesive. Gently run the iron at an angle over each edge and then press the edge down at a slight angle against a firm surface to ensure good adhesion in these areas.

Once the veneer is firmly stuck, trim off the excess using a sharp blade and finish off by sanding the edges (see Edges and Corners).

Method 2 - Using a Press

If a press is available the backing veneer can be applied more simply as follows.

Cut the veneer slightly oversize, 3-5 mm bigger all round than the baseboard. Place several layers of padding, such as blotting paper or newspaper on the lower caul, place a sheet of polythene on top of these sheets and the backing veneer on the polythene.

Apply an even layer of adhesive to the back surface of the baseboard and place this directly onto the backing veneer, ensuring it lines up correctly. Add packing as necessary and slide the assembly under the top caul. Clamp the press firmly and leave until set. Urea-formaldehyde adhesives should be left for 24 hours but PVA will "grab" within a couple of hours and the work should be removed from the press after this time otherwise discoloured spots may appear due to fungal growth or chemical reactions with the water-based adhesive. The work should be left for 24 hours in a warm place to set completely, after which the excess veneer should be trimmed off and the edges sanded as above.

Applying the Edges

It is possible to glue on edges using various configurations of clamps and wedges, but the beginner is likely to find the iron-on method adequate. The edges of the baseboard must be carefully prepared (see Edges and Corners) and the top and bottom veneers and baseboard edges pre-glued (see Ironing On).

The veneer is then ironed on from one end, taking care to apply heat and pressure to all exposed ends and edges. Once the top and bottom veneers are in place the excess is trimmed off using a sharp knife. This is best done by pressing the corner to be trimmed down onto the cutting surface at a slight angle so that the pressure is concentrated at the edge, thus protecting the veneer. If necessary, the sides should be sanded again before pre-gluing ready for the application of the side veneers.

Rubbing Down

The finish which can be achieved on a piece of marquetry is largely dependent upon the care taken over the preparation of the veneer surface. The aim is to produce a perfectly flat surface and to do this the abrasive paper must be held over a firm, flat block. Using abrasive paper with the fingers simply rubs rough irregularities into smooth ones! Indeed, the surface may get more irregular as softer veneers will rub away faster than hard ones (as shown).

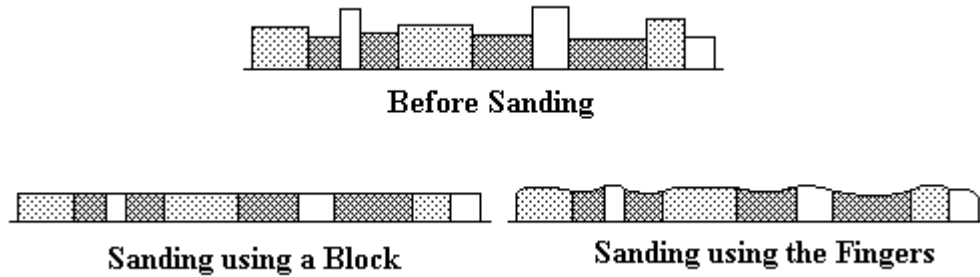

Sanding needs to be carried out carefully by hand. Machine sanding, except in very skilled hands, carries a great risk of spoiling all your hard work very quickly.

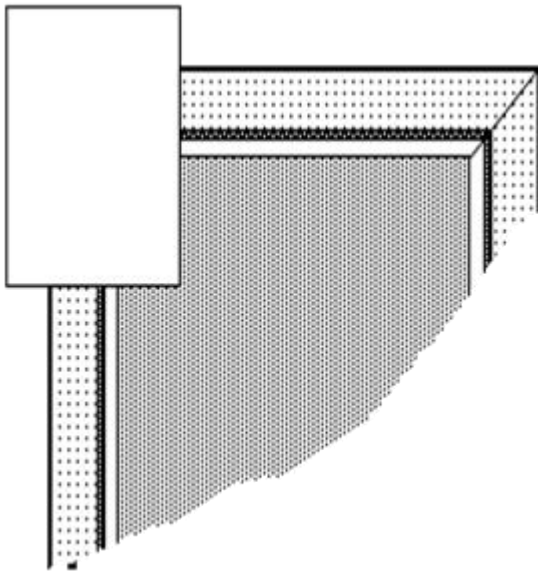

Care must be taken not to over-rub at the edges and corners. A block at least 3" square is needed and must not be moved more than 1" over any edge, as shown.

Abrasive papers

A wide variety of abrasive papers are available, but the beginner requires very few. Initial rubbing down should be done using 150 grit garnet or silicon carbide paper (NOT "sand paper") and this should be followed by the finer 240 or 320 grit.

Method

Sand the back of the picture first, otherwise there is a chance of damaging the sanded face of the picture whilst doing the back. Sand the edges using the sliding block method (see Edges and Corners).

Rub back and forth in the direction of the predominant grain of the picture. Keep a gentle, even pressure and move over the entire picture so that the surface is removed evenly.

Removing Dust

Having sanded the back, face and edges the resulting dust must be removed to restore the true colour of the veneer. This is best done using a small, soft wire brush of the type used for cleaning suede. Gently brush in the direction of the grain whilst blowing away the dust (or draw it up using a vacuum cleaner nozzle).

Polishing

There are various ways of producing the final polished surface on a marquetry picture, each having its champions. The method described here, using a cellulose-based sanding sealer, is relatively simple for the beginner to attempt and allows some degree of "rescuing" should things go wrong! Cellulose based sanding sealer is widely available, both commercially from DIY stores and industrially.

Safety Warning

Sanding sealer, and many of the other surface coatings available, are solvent based. They rely on evaporation of the solvent for the setting and hardening process. Ensure that you work in a well ventilated area and do not smoke. Always follow any instructions on the container.

Applying the Sealing Coat

The application of the first coat is the most exciting time - for the first time you will see the true colours of the veneers and get an idea of the final appearance of your picture.

Find a low block which will support the picture to within about 1/2" of the edge and cover the block with a clear (un-printed) plastic bag. Place the picture face down on the block, which will allow the edges and back to be coated together.

Mix the sanding sealer well, but do not shake it as this introduces small air bubbles which will cause imperfections in the surface. Pour off a small quantity into a shallow dish or jar and reseal the main container. Do not return any unused sealer to the main container as this may introduce dust and specks. Wearing "rubber" gloves to protect the skin, or at least one finger cut from a glove, dip your finger into the sealer and rub it firmly into the back surface, keeping moving until the sealer just starts to go tacky. Continue over the entire back and edges.

Leave the work for about 15-20 minutes until the surface is touch dry, then turn the picture over, the plastic bag over the block will prevent the coating sticking. Coat the face of the picture and the edges in the same way. The edges therefore receive twice as much coating as the back and face. Leave the work for another 15-20 minutes again.

Further Coats

Now that the surface is "sealed" a layer of sealer must be built up.

Turn the picture face down again. Pour on about a tea-spoonful of sealer and spread it gently over the surface using a piece of veneer or plastic - an old credit card is ideal. The process is similar to spreading a thick layer of honey onto rather soft bread! there will almost certainly be some dribbles which run down the sides - smooth these out and coat the edges with a gloved finger as before.

The thicker layer will probably require about 30 minutes to dry off before the work can be turned and coated on the other side. Continue until both surfaces have received about 6 coats. The work must now be left for the sealer to harden fully. This will take at least 72 hours, but if possible leave the picture for several weeks. As the solvent evaporates the sealer shrinks and soon the grain of some veneers (and any open joints if you had any) will show on the surface. This does not matter.

Smoothing

Sanding sealer does not form a particularly tough coating and therefore the end target is a thin layer. To achieve this the surface is cut away using "wet and dry" abrasive paper.

Wrap a piece of 300 grit paper around a block, sprinkle a few drops of water onto the back of the picture and rub gently, ensuring that the entire surface is rubbed evenly. Lubricate the block with a tiny drop of washing-up liquid if it starts to "stick" as the surface becomes flatter.

Dry the surface and examine it against an oblique light. It should appear uniformly dull, but will probably have some small glossy spots. These are areas where the sealer is lower than the surface and has not yet been rubbed down. The choice is between continuing rubbing down, which may expose "bare" veneer and require more coats to be added, or applying more coats anyway and rubbing down again. Every marquetarian has, at some stage, rubbed right through the finish to the veneer and had to add further coats, so don't be dispirited if things don't go right first time!

Once the surface is almost flat, with just the tiniest glossy spots remaining, change to 600 grit paper, still used wet, until the surface is uniformly flat.

Matt or Gloss?

The choice of matt or gloss surface depends upon the nature of the work and personal preference. The matt or satin finish is easier and quicker to achieve, and also hides minor imperfections better than a high gloss finish.

Matt Finish - A matt finish is obtained by rubbing over the sealer surface with very fine (0000 grade) wire wool and a little wax furniture polish. Keep the strokes gentle and in the predominant direction of the underlying grain.

Satin Finish - Various grades of sheen can be achieved by gently burnishing the matt finish with a soft, dry duster.

Gloss Finish - To achieve a gloss finish the sealer surface must be burnished using an abrasive cream such as brass cleaner (e.g. "Brasso") or car colour restorer (e.g. "T-Cut"). Work on areas about 2" square at a time until the whole surface has been treated. Then wash off the surface using warm water and washing-up liquid to remove any residue. Dry the surface and examine. A really high gloss will require considerable elbow-grease.

Care of the Finish

In general only a light dusting is required. Light scratches can be removed from matt surfaces by rubbing with wire wool and wax as above, but gloss surfaces will require complete re-polishing. After 6 months or more the wood grain may show on the surface or cracking may be

apparent. This tends to be more pronounced if the finish is a little thick. The only solution is to sand off the polish, back to the veneer, using fine garnet paper and repeat the finishing process.

Other Finishes

There are a wide range of finishes available. Some of the more commonly used types are described here with a few of my thoughts on their suitability.

Catalytic Lacquer - These finishes, such as Rustin's Plastic Coating, require the lacquer base to be mixed with a hardener before use. They are applied in much the same way as sanding sealer, though each coat must be applied before the previous coat has set hard. They produce a very tough finish which will take a high gloss. The finishes are generally food safe and heat-resistant, making them ideal for "working" items such as cheese-boards.

Tung Oil - Also known as Chinese oil or Danish oil this oil is liberally swabbed onto the surface, allowed to soak in for a few minutes and then the surplus removed. The process is repeated 5 or 6 times at intervals of a few hours. The oil sets by an oxidation reaction and forms a water-proof, matt finish of the type frequently seen on Scandinavian furniture. It does not fill the grain (or bad joints) so is not so suitable for complex marquetry.

Acrylic Lacquers - These "varnishes" are water-based and therefore will cause problems if used directly on the veneer surface, especially if a water-based adhesive has been used! The veneer surface must first be sealed with a coat or two of sanding sealer before the acrylic is applied. Once set hard the lacquer can be burnished to a reasonably high gloss.

Varnishes - In general these give a thick coating which will tend to go yellow with age. They are not generally recommended except for robust outdoor positions - such as house names and numbers.

French Polish - A wonderful finish, but applying it is an art in itself. By all means have a go - if you find an easy way of doing it please let me know! In general French Polished surfaces are not heat or water resistant.

Finishing Off

Hangers

Assuming that your masterpiece has made it this far you will want to display it for all to see., therefore some means of hanging it on the wall is required. Some marquetarians take little care over this aspect of their picture and there used to be a joke in the Marquetry Society suggesting the use of ring-pulls from cans as hangers - until someone actually did it!

There are several types of hangers available and in most cases any are suitable. A few of the commonly used types are described here.

Eyelets and Cord - These are small brass or steel eyelets which are screwed into the back of the picture and which then have brass wire or cord attached to them. The exact positioning on the back of the picture is not critical as long as they are symmetrical. Make sure the length of the screw is less than the thickness of the picture!

Single Loop - This consists of a single brass ring attached by a small shackle which is screwed

to the picture. If not positioned exactly centrally the picture will tend to hang unevenly. This type of fitting can be difficult to attach to some display fittings and for this reason is extremely unpopular with those trying to hang a large exhibition in a short time.

Picture Flanges - These consist of small flat brass plates which are attached to the back of the picture so that part of the flange sticks out. This flange is then used to screw the picture to the wall. These fittings are very good for permanently fixing pictures to walls, especially large ones, but are generally not suitable for pictures which are to be displayed in exhibitions.

Hidden Cord - This is a very neat way of attaching cord which is described in detail in the book by Alan Townsend and David Middleton. Basically two small holes are drilled part way through in the back of the picture (take care!) and then notched dowels are glued in place to secure a knotted cord. This produces a neat fixing which is almost flush. Take care to use strong cord as it cannot be easily replaced should it break.

Protection in Transit

Should you intend to exhibit your work it will need protection. Small pictures can sometimes be packaged in padded posting bags, but these will not protect fully. Far better is to make a simple, sturdy box. There are many possible designs, but two which have served the Marquetry Society well are as follows:

Box 1 - A simple wooden box with sides made from 1" x 1/2" planed timber and a hardboard base, glued and pinned together. The box interior should be about 1" bigger all round than the picture and should be lined with foam or a soft material. The top is simply a sheet of hardboard which is located on a couple of dowels and held in place with large rubber bands, sticky tape or "Velcro" strips.

Box 2 - A box built up to approximately the same size as described above from sheets of corrugated cardboard stuck together with heavy-duty wallpaper paste. The internal opening for the picture can be rather smaller as only a layer of soft cloth, such as a duster, is required to protect the picture. The top and bottom should be at least three layers thick and the sides should be at least 1" wide. The corners should be interlocked for strength.

Details of the construction of the cardboard box are available from the Marquetry Society.
[Goto Contents](#)

Advanced Techniques

Something a little more complicated?

Whilst making your pictures you are likely to find that simple pieces of veneer do not convey the subject to your satisfaction. Over the years marquetarians have developed various techniques for enhancing their pictures and in the following sections I have described a few that I have found useful. Though the end results can look very complex, the techniques are not difficult and are well worth trying.

Sand Shading

Very few surfaces in real life are exactly one colour as seen. We know a newly painted wall is uniform in colour, but we SEE many shades due to shadows. Therefore a simple representation

using one piece of veneer is unlikely to look right. Similarly if the shadows are cut in using a second veneer the joins between the light and dark will not merge as they do in nature. For centuries, marquetarians have addressed this problem by gently scorching light veneers to produce a gradual shading - good examples can be seen in scrollwork on furniture.

Traditionally the scorching medium used is hot sand, though molten lead is also used by some. A fine, "silver" sand is required and should be heated in a shallow pan on a stable hot-plate. The veneer can be dipped into the sand using tweezers or the sand can be ladled onto a sheet of the veneer using a spoon. Nothing is too precise about this method - I have never seen the temperature of the sand mentioned in any text - so the desired effect must be achieved by trial and error.

Simple scorching can also be achieved using a large soldering iron - not a modern electronic type but one of the big brutish things that occasionally turn up in car boot sales. A power rating of at least 85 watts, and preferably 100+ watts is needed. The veneer to be shaded is held just away from the surface of the iron and must be kept in place until the scorching appears on the side furthest from the iron. For crisp dark lines the veneer edge can be touched against the iron.

Shading with both sand or an iron tends to dry the veneer, which may cause cracking or warping. I usually place each shaded piece onto sheets of damp kitchen paper for a few seconds, then remove and dab off with dry paper. If the piece is not to be used straight away it should be placed under a weight to keep it flat. The damp paper restores some of the lost moisture and cools the veneer quickly ready for use.

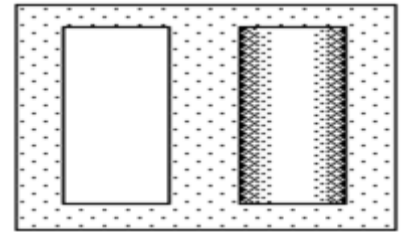

"Rounding" effect produced by shading.

Fine Lines

Sailing ships make ideal subjects for marquetry pictures - lots of action with swirling seas and billowing sails. Unfortunately sailing ships without rigging look very strange, so some effort must be made to represent the web of lines and hawsers.

The technique for producing "fine lines" basically involves making a cut and inserting a sliver of veneer. If there are only a few lines to be inserted then a simple cut is all that is required. However if there are lots of lines then some veneer must be removed, otherwise the width of all the slivers will become significant and cause warping. Generally the cut should be made free-hand, as very few lines are truly straight. Having made one cut a second is made just fractionally to one side, so that a sliver of the background veneer is removed. This requires great care, especially if the cut crosses the grain obliquely as the knife will tend to wander. Remember that more can always be removed, but that what is removed cannot easily be replaced!

The sliver to be inserted is cut from a straight-grained piece of veneer. Colour is not greatly important as it is the effect of the line that will be seen, not the colour. Dyed black veneers are sometimes rather brittle and are best avoided for this work. The sliver is cut from the edge of a sheet using a straight-edge and should be considerably thinner than the thickness of the veneer. Having cut a suitable sliver (which usually takes a few attempts) lay it sideways on the

board and run the knife handle along it to squash it even thinner.

Apply a tiny dab of PVA glue to one end of the sliver and push it into the end of the cut. Ease the sliver into the cut and nick it off carefully at the other end. It may be necessary to ease the cut open slightly to aid insertion of the sliver, but this should not be excessive - if it is then the cut is too narrow or the sliver is too wide! Once inserted, the sliver should be fixed by rubbing in PVA glue as normal.

If you think this technique is fiddly, spare a thought for the marquetarian who produced a beautiful picture of blackberries, each berry with highlights, shading on the leaves and individual thorns on the stalks, and then cut a cobweb over the whole thing. The result was stunning - but what courage!

Bricks

Brick walls often appear in pictures and representing bricks in veneer is not particularly easy. If the wall is in the distance the best solution is to use a mottled veneer, such as Lacewood (Platanus spp.). However if the wall is in the foreground then more attention to detail is required.

The technique is to first cut in a mid-colour veneer to represent the mortar and then cut in individual bricks by the window method. Care is needed to keep the courses of bricks straight and the bricks the same size (allowing for perspective if relevant).

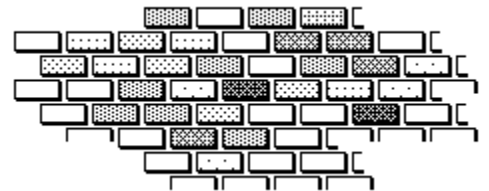

Bricks are not all identical, therefore a selection of similar veneers is required so that a random pattern is achieved.

Care is also needed to take the effect of light into account. If there is a strong angled light across the wall then some shading is necessary to highlight the mortar. This can be achieved fairly simply by touching the bottom and one edge (be consistent) of each brick against a hot iron to just darken them before insertion.

Tiles and Reflections

These are seemingly rather different subjects, but one crafty technique can produce very effective marquetry representations of both roof tiles and reflections. Select a piece of veneer to represent the tiles, for best effect it should have a straight, reasonably pronounced figure. Cut a piece at least 1" larger all round than the roof area to be "tiled", keeping the grain direction at same angle as the roof.

Cut the veneer across in strips at a spacing appropriate to the tiles in the picture. If the roof is "old" then the spacing can be more irregular. The veneer strips will be quite

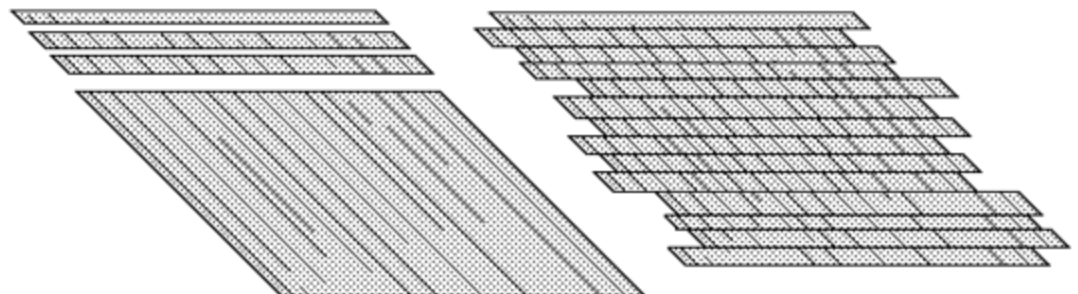

brittle and need to be handled carefully. Assemble the pieces against a straight-edge (see Assembling Borders & Stringers) introducing a slight stagger between each row (as shown).

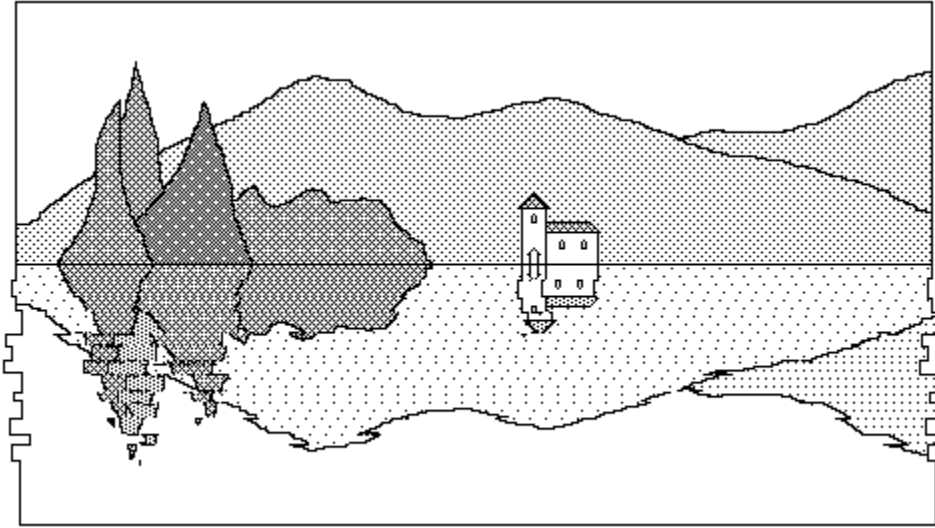

The stagger should not be too even. When the whole piece has been cut and re-assembled, rub in a little PVA glue to hold it all together. Finally, cut in the roof as one piece, taking care to keep the lines of cuts and grain in the correct orientation.

Reflections are produced using the same technique. First, both the picture and its reflection must be cut as normal. Note that the colour of the reflection must compliment the scene, usually it will be a few tones darker, and not every detail is needed. Then the reflection area is cut into strips parallel with the horizon and staggered as before. The strips should be quite narrow and the stagger must not be too regular. The end result can be very effective.

Changing the Colour of Veneers

In general, marquettarians try to make their pictures using the natural colour, figure and grain of the veneers available to them. However, there are ways of altering veneers and a few are described here. Some purists may consider some of these

methods as "cheating", but really there are no hard and fast rules. One thing I would recommend though, is that all veneers, natural or artificially coloured, be used sympathetically with the subject.

Harewood - In the days when logs were transported by floating down rivers and sawn on water driven saw-mills the sawyers noticed that if the logs were left in the water for a long period the resulting timber was often more grey in colour. The effect was particularly pronounced when the water was rich in iron.

The colour change is produced by iron salts in the water reacting with tannins which occur naturally in some wood to produce dark coloured compounds similar to old fashioned ink. The process is now controlled and a range of harewoods in various shades of grey are available commercially.

They are very attractive and blend well with natural veneers. As the process mimics a "natural" reaction most marquetarians are happy using harewoods. It is possible to produce your own harewood by immersing strips of veneer in solutions of ferrous sulphate. Some veneers react much better than others, so trial and error is the order of the day. Some marquetarians have had some success from soaking rusty nails in vinegar and then using a dilution of the resulting "goo" to treat the veneer.

Dyed Veneers - These are available in a range of colours which tend to be rather gaudy. Their use in "normal" marquetry is rather limited, but they can look very effective in cartoon subjects for children's pictures. The dyed blue veneers can be useful for kingfishers - a favourite marquetry subject - but should be avoided for sky or water as they rarely look right. At least one marquetarian has produced his own dyed veneers using colour-fast fabric dyes. Again some experimentation was needed, but a range of colours more subtle than usual was achieved.

Bleaching - There are some commercial wood bleaches available, which will take out much of the colour from a veneer. In general the marquetarian should have a veneer close to the desired colour already available, so the use of bleaches would only be indicated if a particular figure of veneer was required. Domestic bleach will lighten some veneers, but tends to weaken the internal structure of the wood and must be rinsed out thoroughly before the veneer is allowed to dry.

Colourwood - This is produced by injecting dye into living trees, which are subsequently felled and cut into veneers. The effect is much more "natural" than dying as the colour is more randomly spread. Colourwood is expensive to produce and not always easily available, so always have a look at any you find for sale.

[Goto Contents](#)

Parquetry

What is Parquetry?

Parquetry is the use of geometric designs in marquetry. It is particularly applicable to game boards, but can equally be applied to a large table or a pair of earrings. There are numerous techniques for producing parquetry designs and there is not space to cover them all here. Therefore a few examples, not necessarily the simplest, are described to whet your appetite.

Cutting Jigs

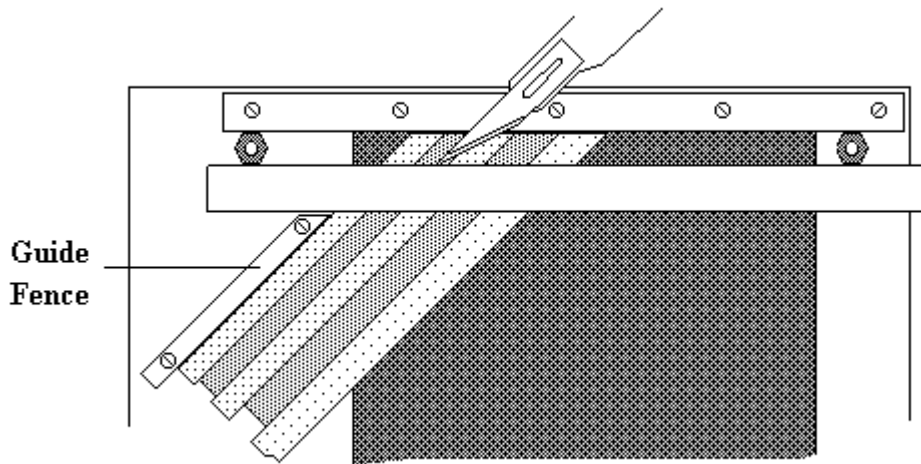

Accuracy is vital to successful parquetry, therefore a cutting template is essential. The jig described earlier (see A Simple Cutting Jig) can easily be modified to allow accurate cutting of 45° , 60° and 90° angles - the most commonly used. All that is required a guide fence (as shown) which can be moved to give the required angles. Care must be taken that the whole assembly is rigid and accurate.

To cut 45° or 60° diamonds the veneers are first cut into strips, which are then assembled together as shown.

The guide fence is set at the required angle and the strips butted up to it. The diamonds are then cut using the same spacers. Care is required when cutting thin strips that they do not flex away from the guide fence under the pressure from the knife, a waste strip on the outer edge of the pack of strips will help, and a sharp knife is essential.

Chess Board

A chess board would seem to be the simplest item of parquetry possible. In some ways this is true, but if you attempt to make one by cutting and assembling the 64 squares, even using a jig, you are likely to be disappointed. The trick is to work in strips, which avoids the cumulative errors arising from cutting individual squares.

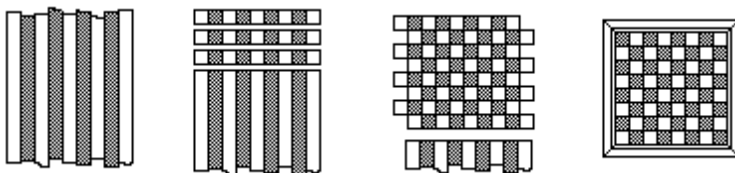

Take 5 strips of the light veneer and 4 of the dark, each cut accurately to the required width of the squares (usually 1.25" or 1.5") using suitable spacers on the cutting jig. Each strip must be at least 9

"squares" long.

Assemble the strips alternately and trim one end exactly square. Using the same spacers cut across the strips to produce alternate light and dark squares, then stagger every alternate strip to produce the checker-board effect. Trim off the surplus light squares and add borders and stringers as required.

Basket Weave

Basket weave patterns are ideal for decorating small items of applied marquetry such as coasters and jewellery boxes. There are basically two ways of producing weave patterns, cutting in individual pieces or unit assembly along similar lines to the technique used for reflections.

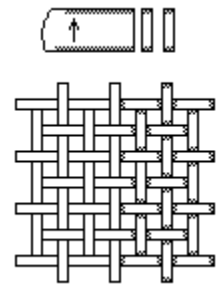

an open weave design from individual pieces

Individual Pieces

This method is used to produce an "open" weave design through which a background veneer can be seen.

A strip of cross-grain veneer is cut such that the width of the strip equals the length of the pieces required. If desired (and it does make a big difference) the long edges are gently sand-shaded and then the strip is cut into pieces of the correct width. These are cut into the background veneer using the piece itself as a template. Care is required to keep the pieces strictly in line, otherwise the pleasing regularity of the pattern is easily lost. This pattern works well if cut in sycamore over a dark, highly figured veneer such as vavona (*Sequoia* spp.) or burr walnut (*Juglans regia*).

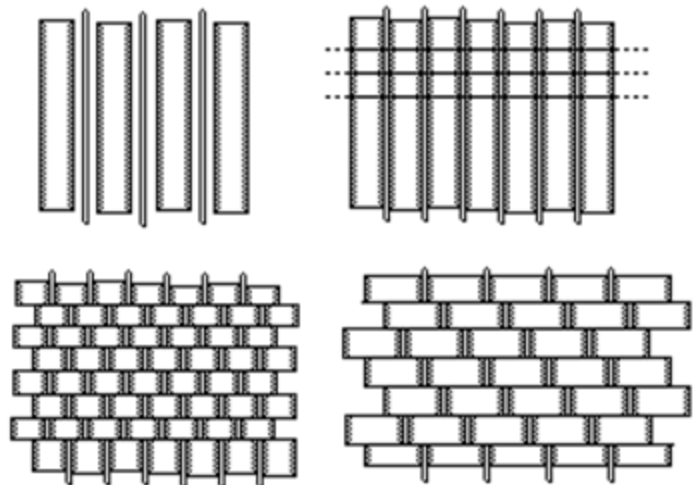

A closed weave design from strip assembly

Unit Assembly

This method produces a range of "closed" weave designs. Strips are prepared and shaded as above, then assembled alternately with thin strips of veneer. The assembly is then cut at right-angles and the strips staggered to produce the weave effect. Again, care is needed to keep the thin strips in line. Different patterns can be achieved by aligning every other, every third or even every fourth strip.

Of course there are more complicated patterns which can be assembled by one or a combination of these techniques.

The Louis Cube



The Louis cube is a fascinating design as it gives a strongly three-dimensional appearance to a flat surface. Three colours of diamond are arranged together to give the impression of a pile of small cubes. It is an ideal pattern for small boxes. Selection of the veneers is a matter of choice, but for a first attempt sycamore (*Acer pseudoplatanus*), pear (*Pirus communis*) and walnut (*Juglans regia*) give a pleasing effect.

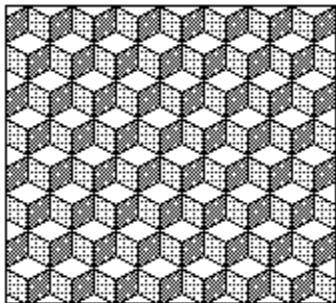

Cutting the Diamonds

On the cutting board, cut strips of veneer using a spacer equal to the required width of the diamond. Tape the strips together side by side and lightly mark the face side with a pencil. Set the fence to EXACTLY 60°, accuracy is vital, and cut off diamonds using the same spacers. Take care to keep all the diamonds the right way up.

Assembling

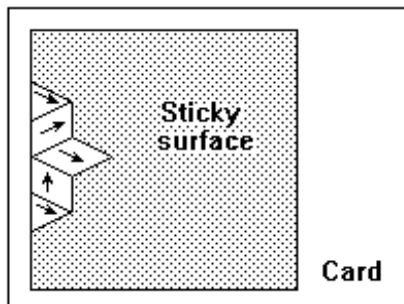

Cut a window slightly larger than the required final size and shape of the pattern in a piece of card. Make sure the left edge of the window is cut exactly straight. Stick masking tape or clear library film on the underside of the card, so that the sticky surface is upwards.

Starting from the left edge, place one dark and one mid-tone diamond, points together, against the straight side of the window. Place a light diamond between them.

The diamonds are best handled by lightly "stabbing" with the point of a sharp knife - very light pressure is all that is used, if the diamond is not picked up then the knife needs sharpening!

Cut a light diamond in half, keeping both pieces the same way up and place them against the side, ensuring that the grain runs in the same direction as the full light diamond already placed. The assembly should now look like the second diagram.

Continue to add diamonds, always keeping the grain in the correct direction until the required area is covered.

Traditionally the three grain directions should all be different, as shown by the arrows in the diagram. To achieve this, one colour diamonds will need to be inverted before placing.

Other Uses for 60° Diamonds

Diamonds and triangles cut with a 60° angle can also be assembled into many other designs which make useful decorative motifs for small boxes and other items. A pattern of alternate 60° diamonds can be prepared in the same way as the chess-board, but using the cutting-board fence set to 60°.

Bibliography

Introduction

The choice of reference books is a very personal matter. The comments below indicate my opinions, but you are recommended to view library copies before committing to purchase.

Art Veneers Manual & Catalogue

The Art Veneer Company, Chiswick Avenue, Mildenhall, Suffolk, IP28 7AY (Telephone 01638-712550) Probably the best value information around. My copy (edition M) has over 100 pages packed with information on veneers, tools, adhesives, polishes and fittings. It includes colour pictures of 50 species of wood - all for a few pounds. Art Veneers Co.

How to Work with Tools and Wood

Robert Campbell & N. H. Mager (Eds.), Pocket Books N.Y., ISBN 0671421913 A useful "workshop guide" of carpentry and cabinet making techniques with hints on the maintenance of tools.

Marquetry

Pierre Raymond, The Taunton Press, 63 South Main Street, PO Box 5506, Newtown, CT06470-9959, USA. The English version (the 1989 original is in French) was re-printed a few years ago. This book has a wealth of pictorial matter, but most of the text concerns saw cutting methods, so at about \$80 US this is one to get from the library first!

Marquetry and Inlay, 18 Decorative Projects

Alan & Gill Bridgewater, TAB Books. ISBN 0830634266 A series of well laid out projects - a good book for ideas.

Marquetry and Veneers

Edward Kitson, Foyles Handbooks. A thin volume almost certainly out of print. Rather dated techniques.

Marquetry for Beginners

Ernie Ives, available via the Marquetry Society A little dated, but an inexpensive confidence-builder full of useful techniques. A video tape is also available.

Marquetry Techniques

David Middleton & Alan Townsend, Batsford Ltd. ISBN 0713469862 An excellent hard-back book, packed with useful hints and well explained projects. A useful follow-on to "Marquetry for Beginners".

The Art and Practice of Marquetry

William A. Lincoln. Thames & Hudson. Now out of print, having been re-written as "The Marquetry Manual".

The Encyclopaedia of Wood

William Lincoln [et al], Facts on File Books, ISBN 0816021597 A sumptuous hard-back book packed with information on hundreds of species of wood. Many excellent colour photographs.

The Fascination of Marquetry

Clifford Penney. A general introduction.

The Marquetry Manual

William A. Lincoln, Stobart & Son Ltd. ISBN 0854420428 The "bible" for all things marquetry.

The Technique of Marquetry

Marie Campkin. Batsford Ltd. ISBN 0713461349 A good general introduction.

The Technique of Wood Surface Decoration

David Hawkins, Batsford Ltd. ISBN 0713445017 A description of various marquetry and inlay techniques, with the emphasis on furniture and restoration. The illustrations can be a useful source of ideas.

Goto Contents

Glossary of Terms

1. *Cauls* - The two bearing surfaces of a press between which a picture is clamped during gluing.
2. *Figure* - The pattern on the veneer, which is determined by various factors such as the direction of cutting relative to the grain, natural colour variations and features such as knots or insect marks.
3. *Flitch* - Part of a log, cut lengthways before slicing into veneers.
4. *Grain* - The arrangement of wood fibres in relation to the main axis of the tree. This should not be confused with the figure of a veneer.
5. *Miniature* - To be exhibited as a miniature at the Marquetry Society's National Exhibition a marquetry picture must have a face area, including borders, of not more than 12 square inches.
6. *Veneer* - A thin sheet of wood, typically around 1 mm thick.